

# PRODUCT INFORMATION PACKET

**marathon**<sup>®</sup>  
Motors

Model No: 256TTFL4031

Catalog No: U354

20 HP Close-Coupled Pump Motor, 3 phase, 1800 RPM, 230/460 V, 256JM Frame, TEFC  
JM Motors

Regal and Marathon are trademarks of Regal Beloit Corporation or one of its affiliated companies.  
©2020 Regal Beloit Corporation, All Rights Reserved. MC017097E

**REGAL**

### Nameplate Specifications

Output HP	20 Hp	Output KW	14.9 kW
Frequency	60 Hz	Voltage	230/460 V
Current	51.0/25.5 A	Speed	1750 rpm
Service Factor	1.15	Phase	3
Efficiency	91 %	Power Factor	81
Duty	Continuous	Insulation Class	F
Design Code	B	KVA Code	G
Frame	256JM	Enclosure	Totally Enclosed Fan Cooled
Thermal Protection	No	Ambient Temperature	40 °C
Drive End Bearing Size	6309	Opp Drive End Bearing Size	6207
UL	Recognized	CSA	Y
CE	Y	IP Code	43

### Technical Specifications

Electrical Type	Squirrel Cage Induction Run	Starting Method	Across The Line
Poles	4	Rotation	Reversible
Resistance Main	.45 Ohms	Mounting	Rigid Base
Motor Orientation	Horizontal	Drive End Bearing	Ball
Opp Drive End Bearing	Ball	Frame Material	Aluminum
Shaft Type	JM	Overall Length	28.49 in
Frame Length	14.75 in	Shaft Diameter	1.250 in
Shaft Extension	5.28 in	Assembly/Box Mounting	F1/F2 Capable
Connection Drawing	A-EE7308	Outline Drawing	B-SS330112-1475

This is an uncontrolled document once printed or downloaded and is subject to change without notice. Date Created:03/11/2020

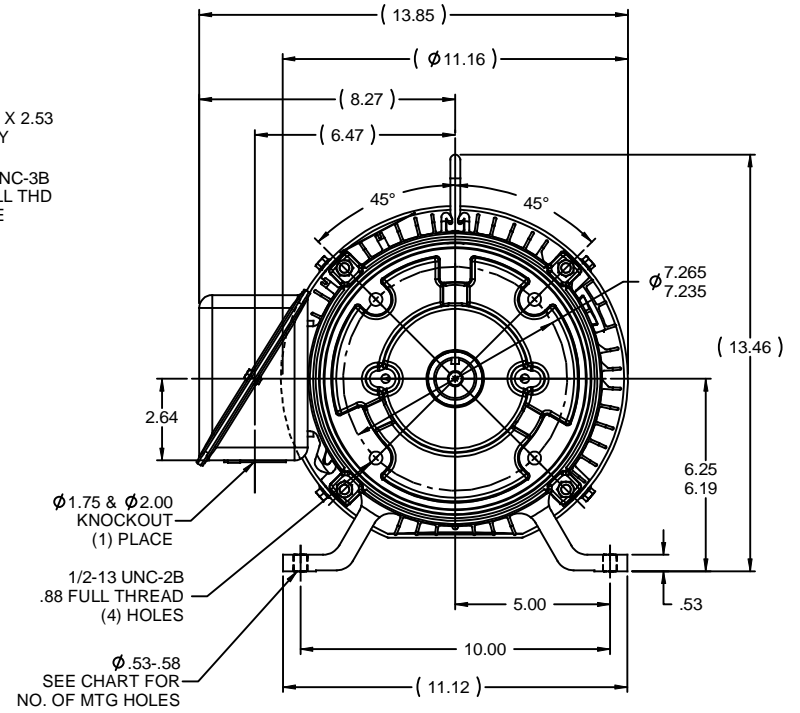
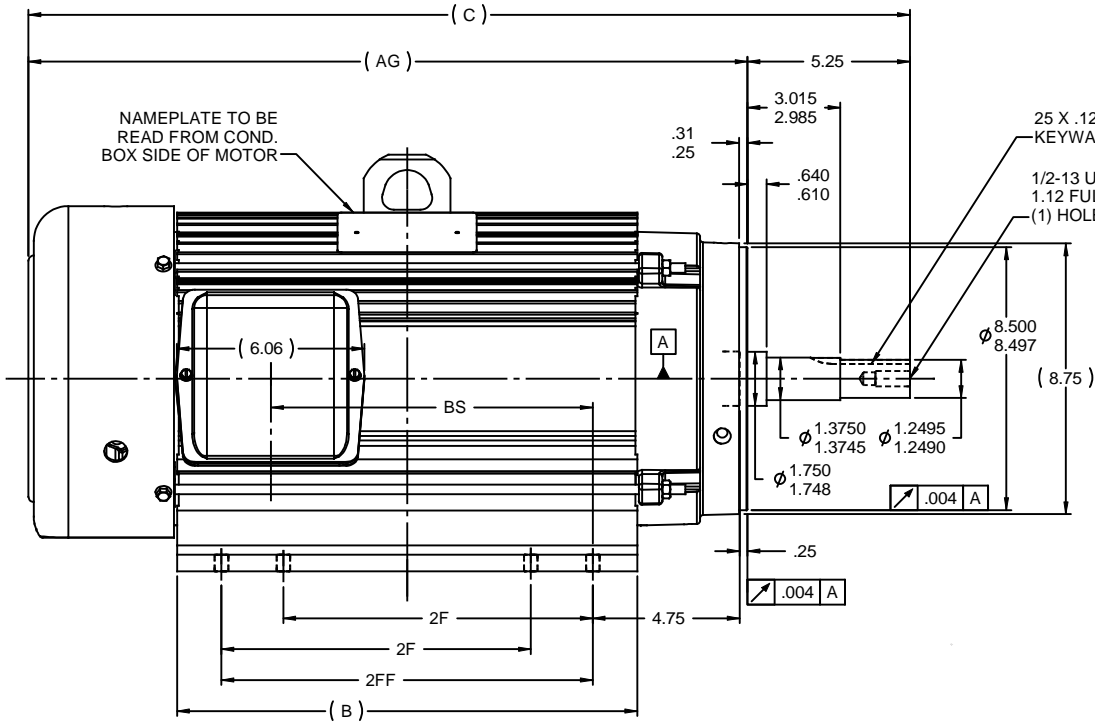

- NOTES:  
 1) BOX CAN BE ROTATED IN 180° STEPS  
 2) SEE CHART FOR F2 CAPABILITY. IF YES; BOX CAN BE MOUNTED ON OPPOSITE SIDE BY REMOVING BRACKETS AND TURNING FRAME 180°  
 3) NAMEPLATE TO BE READ FROM CONDUIT BOX SIDE OF MOTOR

DASH	FR.	C	B	2F	2FF	AG	BS	F1/F2	NO. OF MTG HOLES
1100	254	24.74	11.12	8.25	---	19.49	6.65	YES	4
1150	254	25.24	11.67	8.25	---	19.99	7.15	NO	4
1275	254/6	26.49	12.87	8.25	10.00	21.24	8.40	YES	8
1275A	256	26.49	12.87	10.00	---	21.24	8.40	YES	4
1325A	254	26.99	13.37	8.25	10.50	21.74	8.90	YES	8
1325A	256	26.99	13.37	10.00	---	21.74	8.90	NO	4
1475	256	28.49	14.87	10.00	---	23.24	10.40	YES	8

		TOLERANCES UNLESS SPECIFIED		MARATHON ELECTRIC		DRAWN DRS 02-27-2006	
		DEC	INCHES			CHK	ML 02-27-2006
3	CLARIFIED DASH 1275 & 1325 MTG HOLES CN09-3560	TJW	9/18/2009	CTO	x	±.1	APPR BW 02-27-2006
2	REVISE THE DASH 1275 & 1325 ON CHART	RWR	12-26-2007	ML	xx	±.03	SCALE 1:4
1	RE-ISSUE - ADD 4/8 MTG. HOLES TO CHART AND RE-POSITION VIEWS SO TEXT CAN BE READ EASILY	RWR	07-11-2007	ML	xxx	±.005	REF SS84286
					xxxx	±.0005	FMF
NO	REVISION	BY & DATE	CHK	ANG	±7'30"	FINISH	PREV
THIS DRAWING IN DESIGN AND DETAIL IS OUR PROPERTY AND MUST NOT BE USED EXCEPT IN CONNECTION WITH OUR WORK. ALL RIGHTS OF DESIGN AND INVENTION ARE RESERVED. THIS IS AN ELECTRONICALLY GENERATED DOCUMENT - DO NOT SCALE THIS PRINT		RFP	02-27-2006	CAD FILE	SS330112	SIZE	DRAWING NO
		DIST	LB			B	SS330112
						REV 3	

EE7308

THREE PHASE  
DUAL VOLTAGE MOTOR



VIEW OF TERMINAL END

REF.  
WINDING DIAGRAM

T8Y, T2Y, T2BL, T4BX, T2EC, T2G  
T6BZ, T2B, T6BL, T4AV, T6B, T4B

OPTIONAL CORD  
CONNECTION

L1 — WHITE  
L2 — RED  
L3 — BLACK

NO.	REVISION	BY & DATE	CHK	ANG	TOLERANCES UNLESS SPECIFIED		FINISH	DRAWN RM 11/20/1990				
					DEC.	INCHES						
5	CHG TO REGAL LOGO	SL 09/10/2015	AB					CHK ML 11/21/1990				
4	REVISED IEC NOTATIONS	MSG 11/15/2011	CMN	.X	±.1			APPD SAS 04/24/2003				
3	ADDED IEC NOTATIONS... (U1), (V1) ETC. MU95194	MSG 5/10/2010	MJS	.XX	±.02		TITLE CONNECTION DIAGRAM	SCALE 1=1				
2	ADDED THE OPTIONAL CORD CONNECTION MU46318	RDH 04/24/2003	DRS	.XXX	±.005		3Ø - DUAL VOLTAGE MOTOR	REF				
1	REDRAWN	RM 11/20/1990		.XXXX	±.0005		MAT'L.	FMF				
					±7'30"			PREV				
THIS DRAWING IN DESIGN AND DETAIL IS OUR PROPERTY AND MUST NOT BE USED EXCEPT IN CONNECTION WITH OUR WORK ALL RIGHTS OF DESIGN AND INVENTION ARE RESERVED THIS IS AN ELECTRONICALLY GENERATED DOCUMENT - DO NOT SCALE THIS PRINT							RFP	CAD FILE ee7308	SIZE A	DRAWING NO. EE7308	PAGE OF 5	REV. 5
							DIST WP					

